

4

3

2

1

REV		DESCRIPTION	DATE	APPD
00		INITIAL ENG RELEASE	9/1/16	MK
01		ADDED DIMS, CLEANED UP DWG	9/6/18	TR

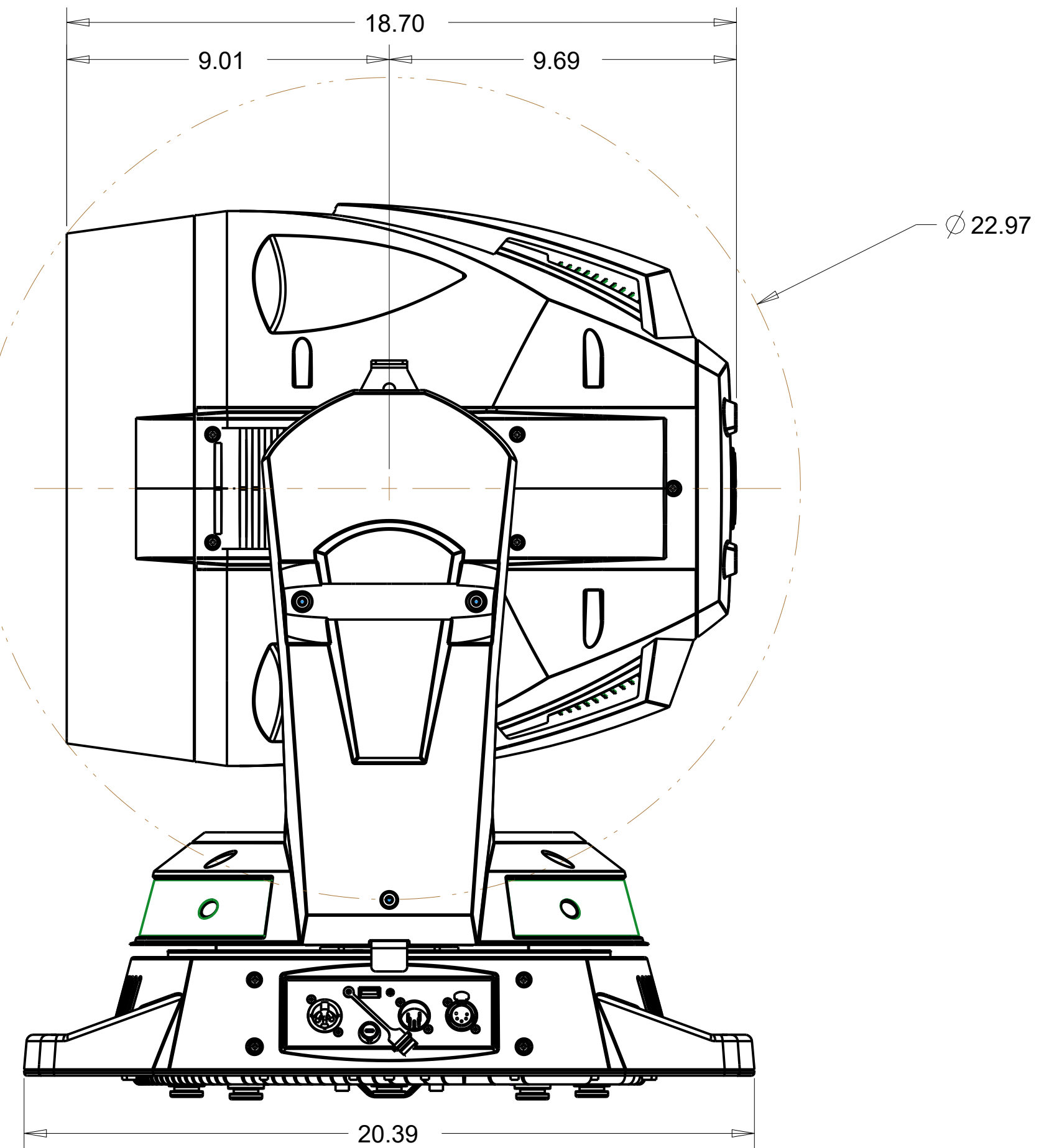
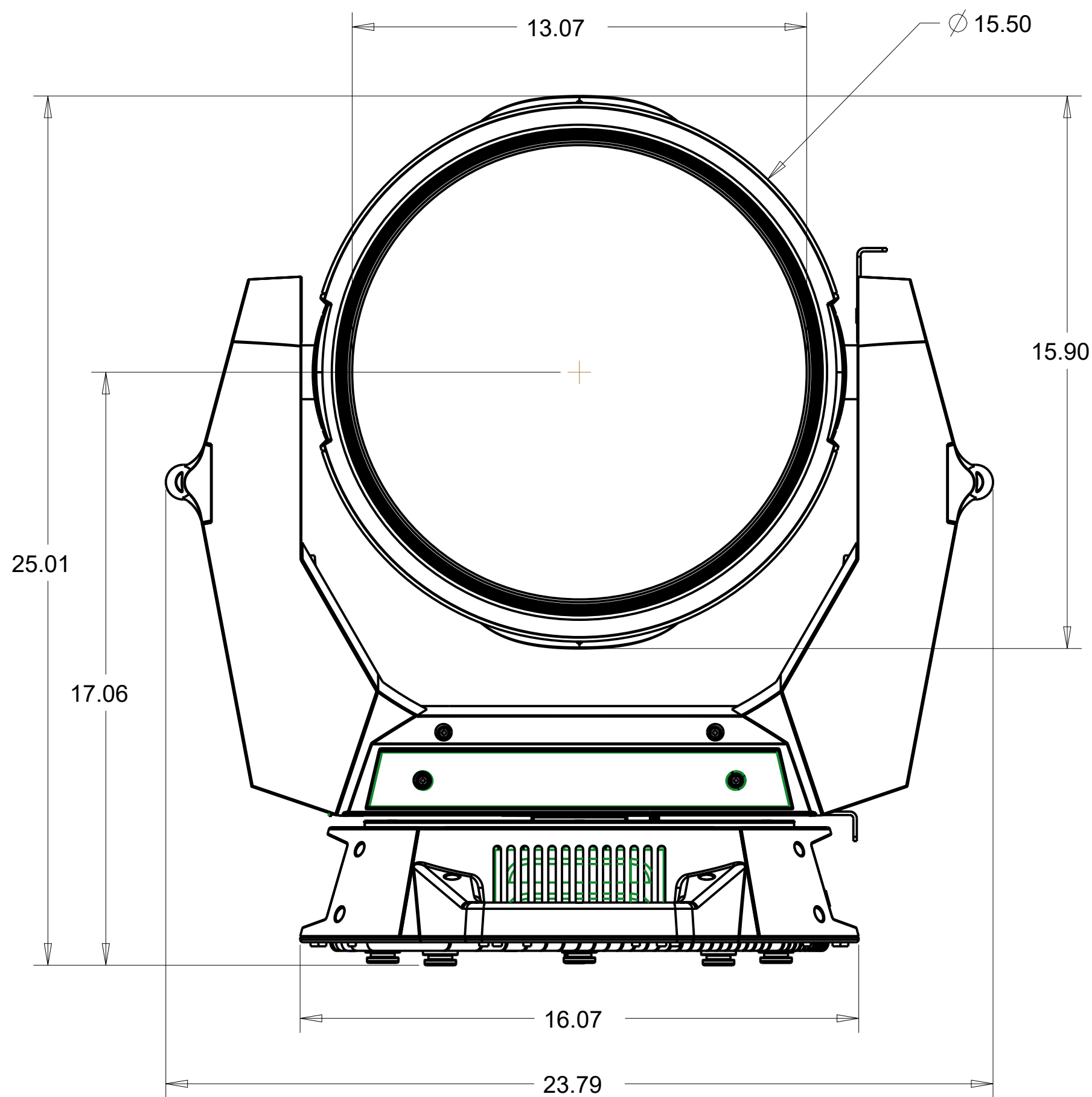
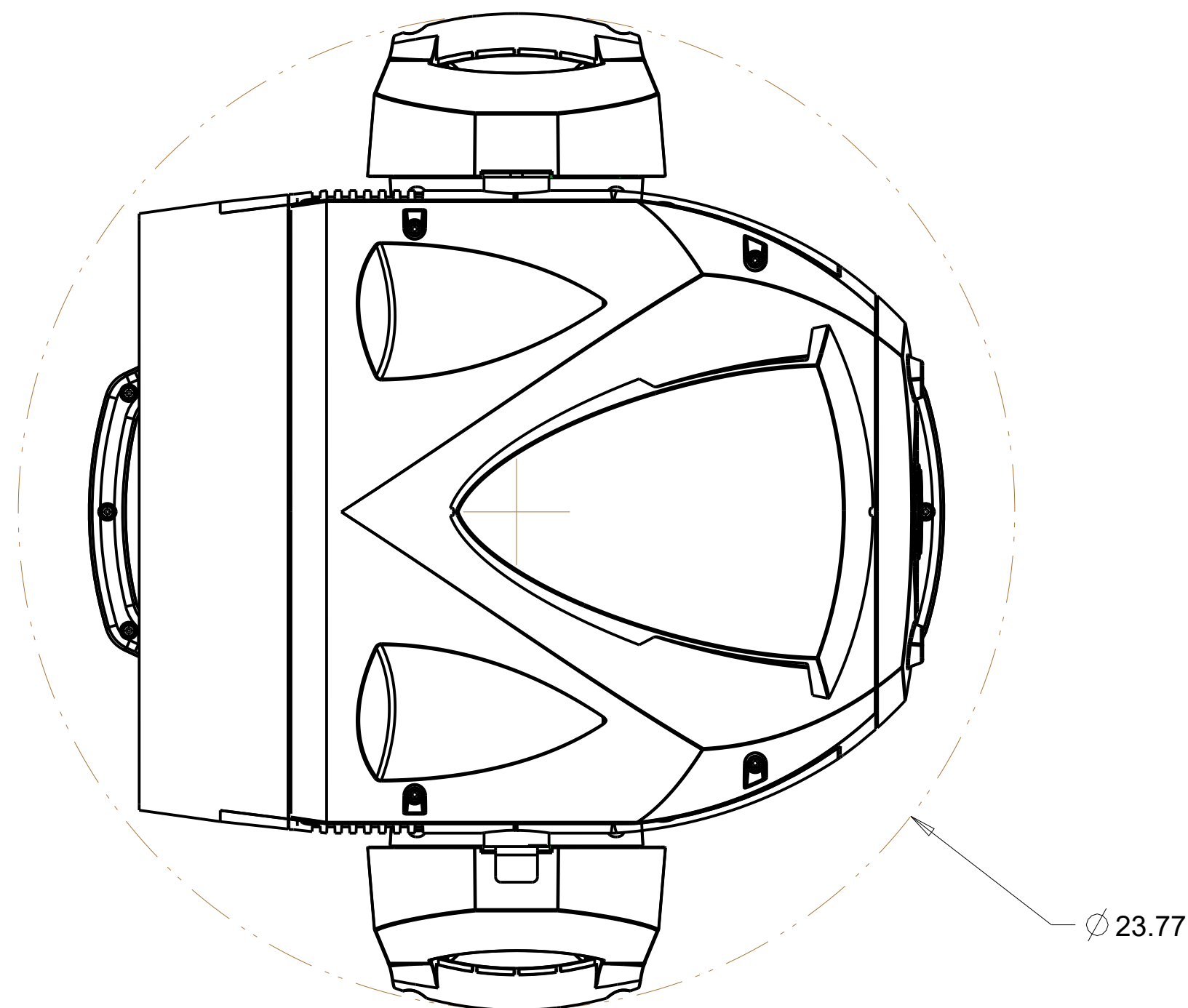
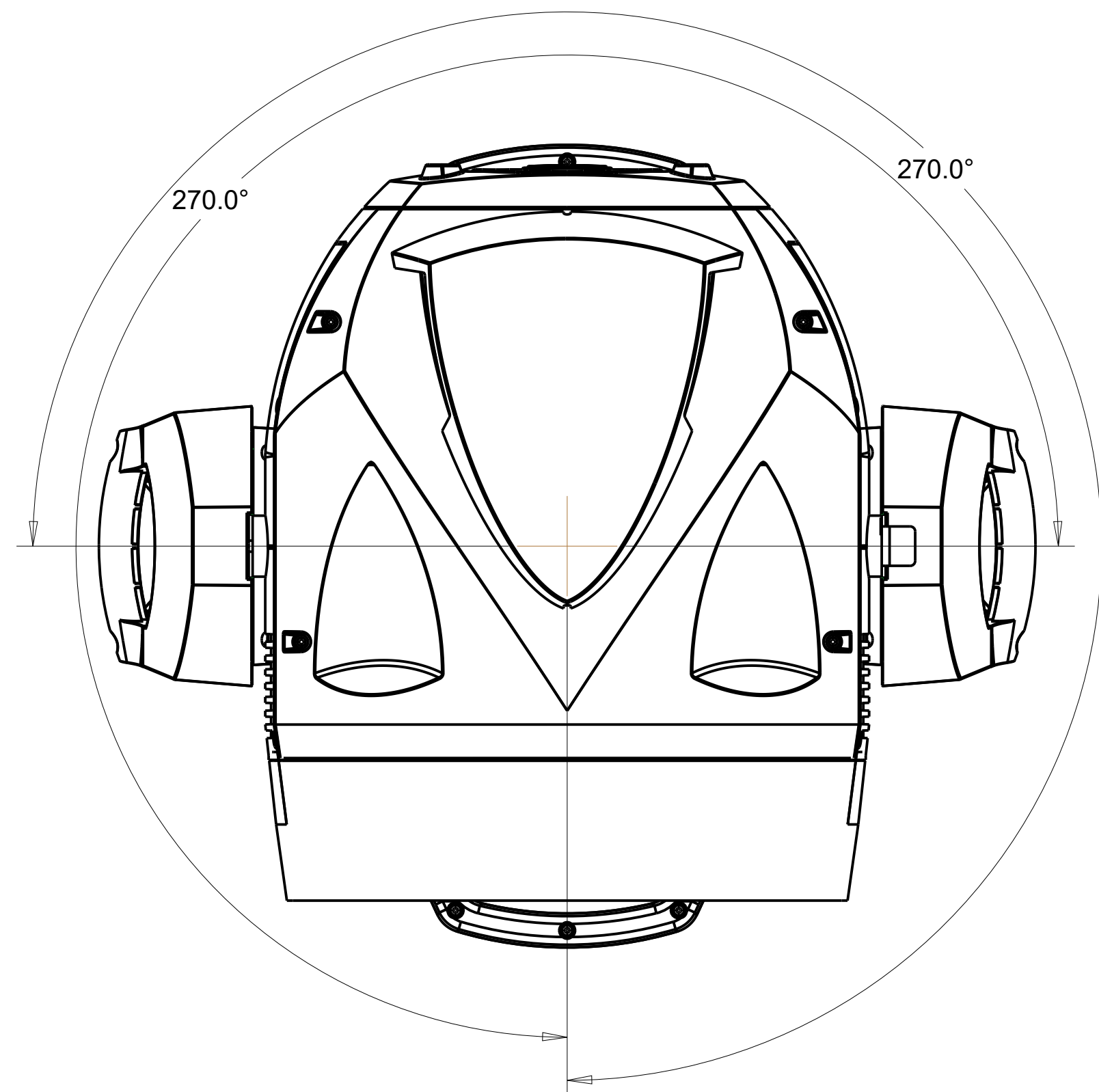

NOTES:

GC SPECS: ALL MATERIAL PROTOTYPES, ARTICLE SAMPLES, AND PRODUCTION LOTS ARE TO BE DELIVERED IN CONFORMANCE TO USE OF THE FOLLOWING PHILIPS DOCUMENTS: QOP-0101 & GC-QA-F033				
NEXT ASSY	TOLERANCE TABLE	X.X° = ± 0.5° X.XX° = ± 0.25°	X.XX = ± 0.020 X.XXX = ± 0.010	PHILIPS ENTERTAINMENT 10911 PETAL ST., DALLAS, TX 75238
MATERIAL		DSN	MK	9/16
FINISH		MATERIALS, PARTS AND PRODUCTS MUST COMPLY WITH THE ENVIRONMENTAL REQUIREMENTS OF PIN 02-9600-0001		
NOTICE:		ALL DIMENSIONS ARE IN INCHES UNLESS NOTED OTHERWISE. REMOVE ALL BURRS AND SHARP EDGES.		
PHILIPS VARILITE ALL RIGHTS RESERVED.		SIZE	REVISION	DRAWING NUMBER
		D	01	16-9708-0002
		SCALE	0.30	PRO/ENGINEER SHEET 1 OF 1

4

3

2

1

REVISIONS			
REV	DESCRIPTION	DATE	APPD
00	INITIAL ENG RELEASE	9/1/16	MK
01	ADD DIMS AND CLEAN UP DWG	9/6/18	TR

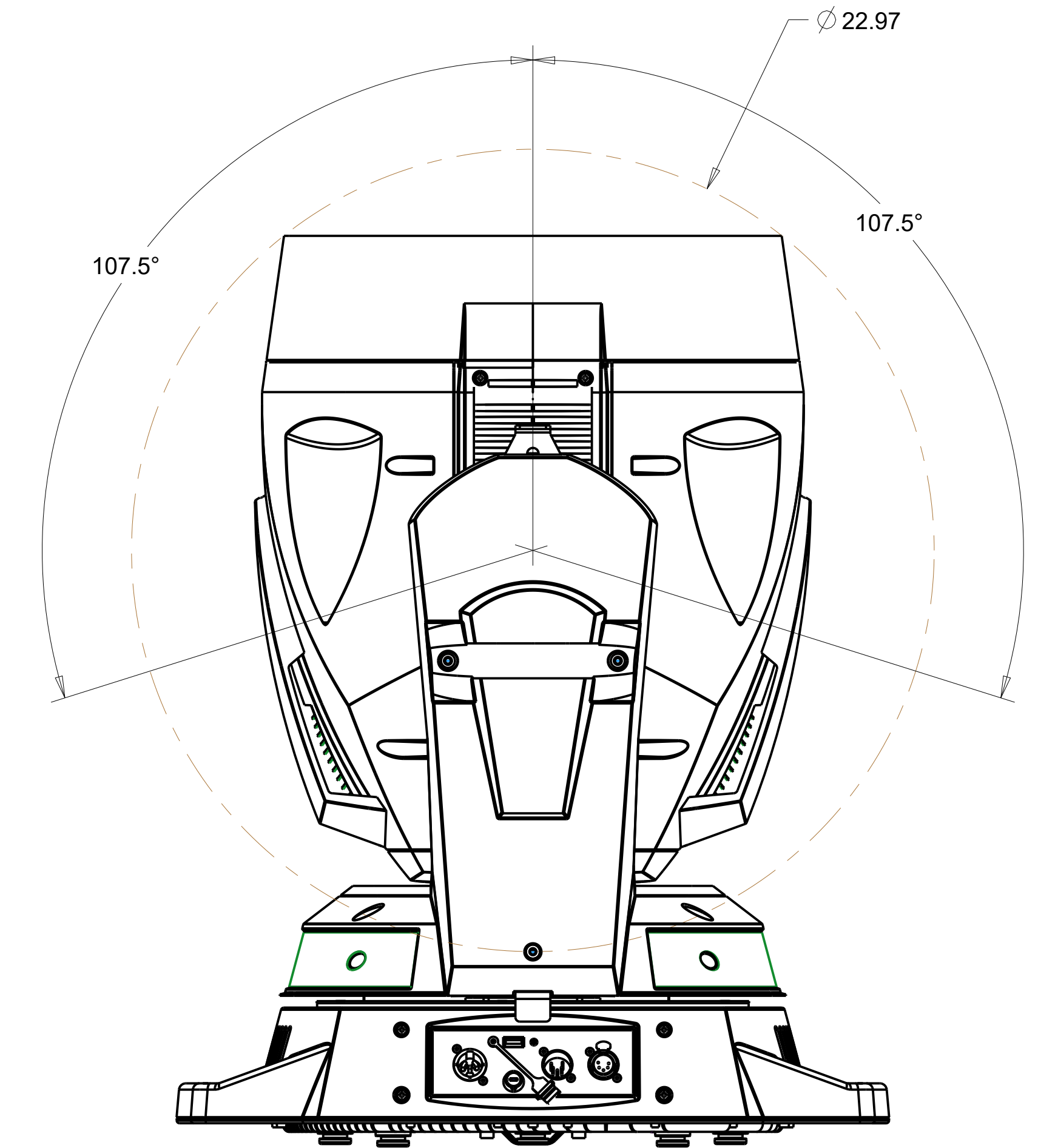
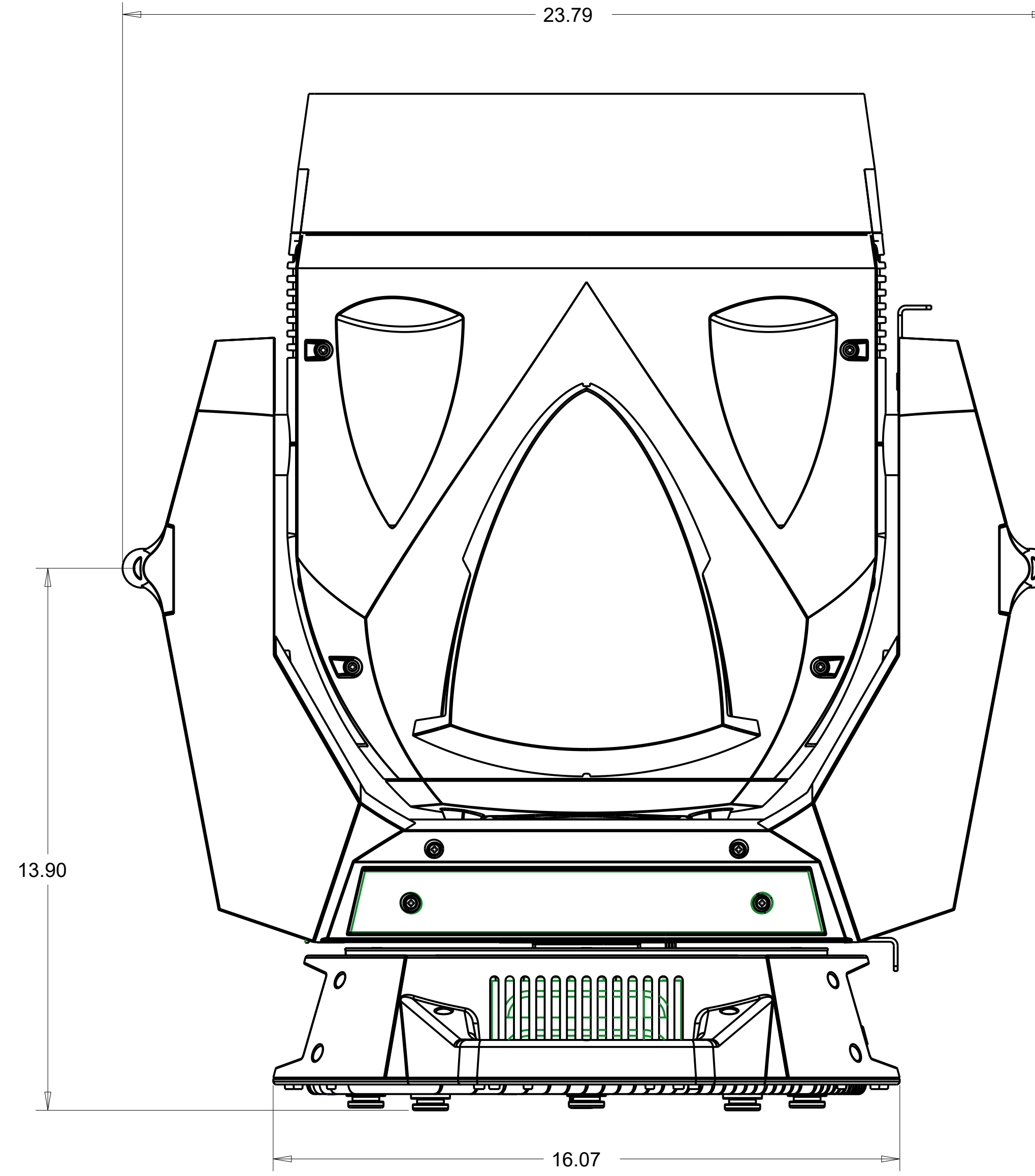
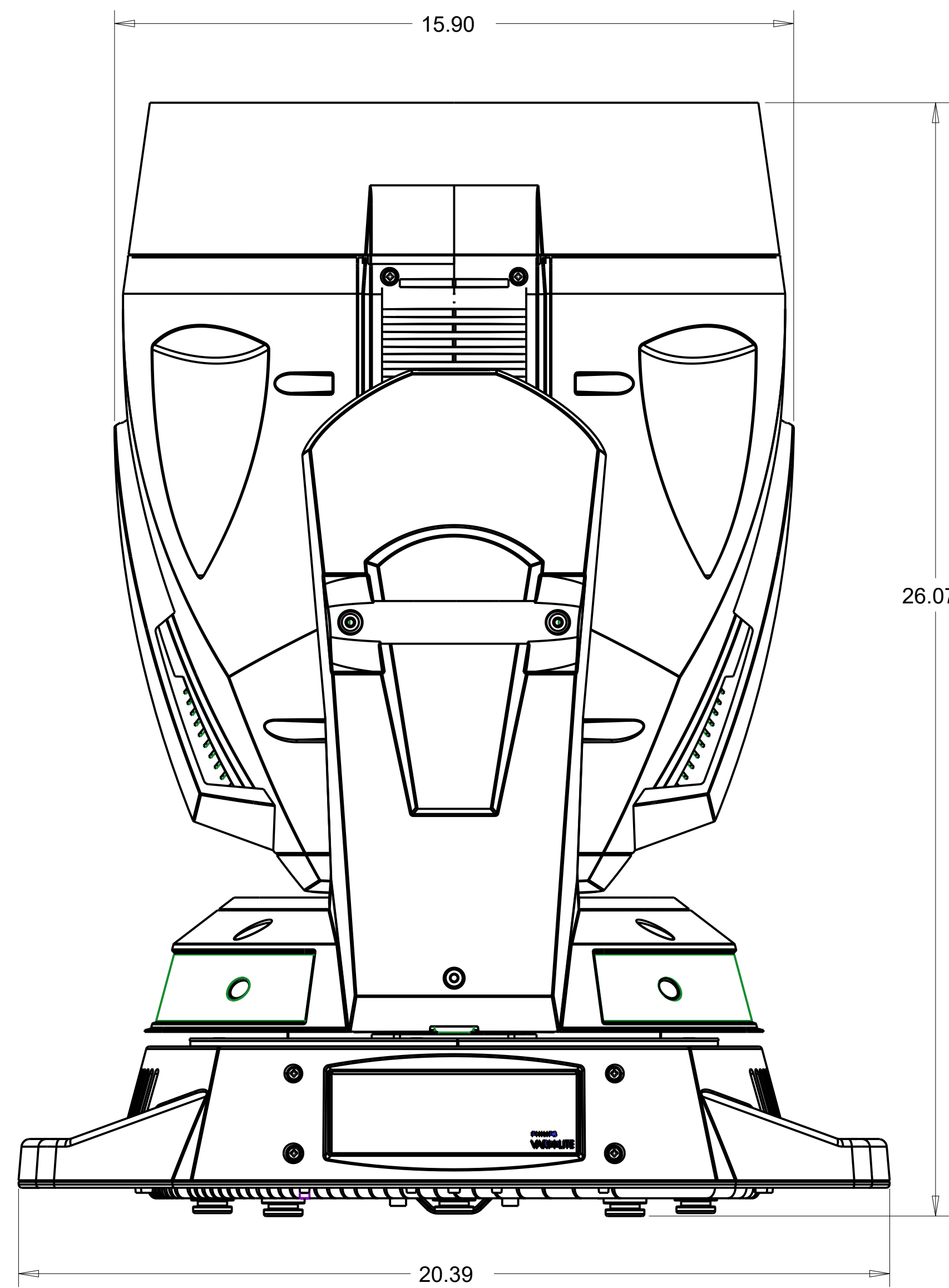

TILT TRAVEL LIMITS
SCALE 0.300

NOTE:

GC SPECS: ALL MATERIAL PROTOTYPES, ARTICLE SAMPLES, AND PRODUCTION LOTS ARE TO BE DELIVERED IN CONFORMANCE TO USE OF THE FOLLOWING PHILIPS DOCUMENTS: QOP-0101 & GC-QA-F033									
NEXT ASSY		TOLERANCE TABLE	ANGLE X° ± 0.50	X.XX ± 0.020 X.XXX ± 0.010	PHILIPS ENTERTAINMENT 10911 PETAL ST., DALLAS, TX 75238				
NOTICE: INFORMATION AND DESIGN DISCLOSED ON THIS DOCUMENT ARE CONSIDERED PROPRIETARY AND SHALL NOT BE REPRODUCED OR DISCLOSED WITHOUT WRITTEN CONSENT. PHILIPS VARILITE ALL RIGHTS RESERVED.		MATERIAL	DSN DWN	MK	9/16	OUTLINE DIMENSION DRAWING, VERTICAL HEAD, VL6000			
		FINISH	MATERIALS, PARTS AND PRODUCTS MUST COMPLY WITH THE ENVIRONMENTAL REQUIREMENTS OF PIN 02-9600-0001		SIZE	REVISION	DRAWING NUMBER		
			ALL DIMENSIONS ARE IN INCHES UNLESS NOTED OTHERWISE. REMOVE ALL BURRS AND SHARP EDGES.		D	01	16-9708-0001		
					SCALE	0.40	PRO/ENGINEER	SHEET	1 OF 1