

Operating Instructions
ALP-Material-Lift
LM/LH/LMC/TL/TLC Models

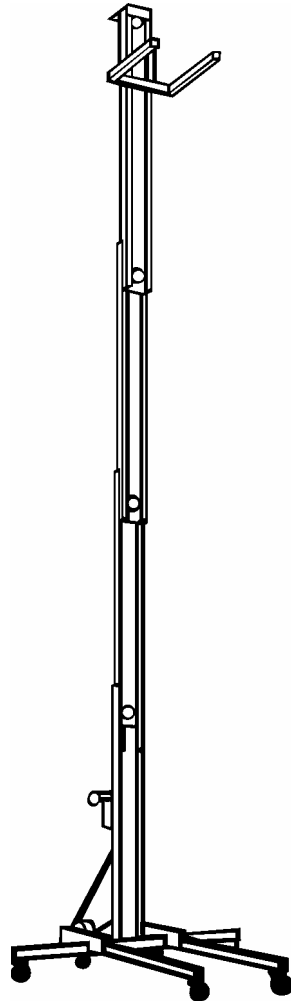

Robert Böcker GmbH

Lippestr. 73 – D-59368 Werne

Phone: ++49 2389 40226-0

Fax: ++49 2389 40226-40

Internet: www.alp-lift.de

1. Description

The ALP-Material-Lift is a mobile load lifting apparatus which can be put into use in closed buildings and on flat surfaces. It's maximum load capacity is, according to lift type:

LM / LM-F	3000 N
LH / LH-F	3000 N
LMC / LMC-F	2500 N
TL-F / TLC-F	3000 N

Models can be with hand winding winch or electro-hydraulic winch according to choice. The sound pressure level is less than 75 decibels.

2. Transport

The ALP-Material-Lift can be transported in vehicles or on trailers either standing, or in lying position, the rails safety device must be notched in (picture 1), the rope taut and the tank ventilation valve (only LH lift) (picture 2) closed, as otherwise the rails could glide apart and the hydraulic oil can escape. The ALP-Material-Lifts is transported with folded up (LMC with upright) chassis front parts and the load fork mounted the other way (picture 3/4/5).

3. Assembly

- Lift types LM/LH-F (picture 7)

First of all assemble the chassis in that the vertical screws (M16 x 170) are loosened with the nut and removed. The front parts are folded down, safety screws are reinserted and screwed fast with the nut.

- Lift types LMC-F (picture 6)

First of all remove one of the front parts from the transport clamping fixture and bring it into the working position (secure with lock pin). After, this the second front part is brought into the working position.

- Lift types TL/TLC-F (picture 8)

Push the 4 stabilizers into the clamping fixture provided for it and secure this with the lock pins. The 2 long outriggers on the load fork side, the 2 short outriggers in the winching side. Finally, adjust the lift vertically using the spirit level. In the case of outdoor use, then corresponding counter weights must be used.

4. Putting into operation

Unbolt the sliding carriage, in that the rail securing is pulled out, turn this in a backward direction and return it to the last rail (picture 1). Open the tank ventilation valve (only LH-Lifts, picture 2). Remove the fork safety bolt and pull the fork out of the sliding carriage. Assemble the fork on the lower or upper side of the sliding carriage (picture 9/10), return the fork safety bolts and screw back. For the TL/TLC lifts move the prongs by 90° to the clamping fixture and secure with the lock pins. Side stabilizers with steering rollers can be mounted for additional stability (LM/LMC 600 / LM 750 they are standard) (picture 11).

5. Operation

Only use the ALP-Material-Lifts on flat surfaces, secure all the stabilizers onto 4 steering rollers and never overload. Material-Lifts must not be driven when loaded. The lifting of the load is carried out by turning the hand lever in clockwise direction. The load is automatically retained when the hand lever is released. To lower the load, the hand lever is turned in an anti-clockwise direction. A recoil of the hand lever is avoided due to built in automatic braking device. Approx 20 m of untensioned rope can be spooled onto the coil drum. Only so much rope can be spooled so that an overhang to the board disc at least 1,5 times the diameter of the rope is guaranteed. Thus, an overload of the winch ,and sideway run-off of the rope from the drum, is avoided. In the case of driving upwards under a load the at least 2 drum turns of rope must remain on the drum.

Rope recommendation: rope \varnothing 6 mm
Individual wire stability : 1770 N/sq. m.
according to DIN 3060 (German Industrial Norms) galvanized

Special notes :

- ALP-Material-Lifts with electro-hydraulic winch

To lift the load first of all the electro-motor must be switched on by means of the engine protective switch (picture 12). The reel is set in motion by the hand steering valve (lever down/load down – lever up/load up – picture 13). When letting go the hand lever or switching off the electro-motor, then the load is automatically retained by means of built-in brakes(Dead Mans Switch). Overloading of the winch, as well as, upper and lower impact (final position) is achieved by built-in switches and/or valves. If the lift is not being used, then the motor is to be switched off immediately, in order to avoid unnecessary wear and tear, as well as, over-heating of the oil.

Important !

Before work begins with the ALP-Material-Lifts then the person operating the lift should be well-aquainted with the equipment and most exactly trained.

6. Unauthorized Use

After finishing work with the ALP-Material-Lifts with hydraulic drive, the winch must be secured by means of the key switch to assure that no unauthorized use can take place.

7. Types of drive

Model	Drive
LM-F	by hand winch
LMC-F	by hand winch
LH-F	by electro-hydraulic winch
TL-F	by hand winch
TLC-F	by hand winch

The electro lifts can be supplied with the following voltage: 110 / 230 / 380 Volt

For the electro-hydraulic drive than the sufficiently calculated supply must be provided: 3 x 2,5 mm² or 5 x 1,5 mm²

8. Monitoring the safety equipment

- Never overload the ALP-Material-Lifts
- Never transport persons with lift, only materials
- Never stand below the load
- Do not use a ladder at, or on the lift
- Be careful of tensed wires, roof appendages or cables above the lift
- The distance to be maintained to electricity supply cables is at least 5 m
- The load centre of gravity should never be more than 330 m from the rear side of the fork
- When using a load fork extension, or in the case of a bulky load then the maximum load, has to be lowered in relationship to the load centre of gravity (see the load diagram)
- In the case of winds, over wind-force 6 on the Beaufort scale, the operation must be stopped
- When lifting loads which are susceptible to wind-force (e.g. air ducts, tin containers), then operation is to be stopped correspondingly earlier
- Never leave the lift unattended with a load winched up
- Check the wire rope-daily in the case of damage stop operations immediately
- It is strictly forbidden to undertake any structural changes to the equipment which could in any way influence safety, ore are not compatible with the with the safety regulations of the authorities

9. Maintenance and Tests

- Check wire ropes before use and when necessary replace them
- In the case of LH lifts the pressure valves must be checked annually by a competent person
- Check the oil level in the hydraulic often, refill when required. Undertake an annual inspection and a competent oil change (LH lift)
- After about 20 operational hours check all hydraulic screw connections for tightness, if necessary retighten (LH Lift)
- Protect the lift from dirt, rain and other influences of the elements. The aluminium mast elements should also be protected from dirt and rubbish.
- Protect the inner sides of the mast with silicon spray
- Check the synthetic rollers and rope rollers for wear and tear damage
- The hand winch comes already greased from works. But the thread on the hand winch must always be greased. It is recommended that the bearing bushes on the driving shaft and the drum hubs are oiled regularly.
- It is important to grease the gear rim on the winch
- **Attention ! Do not oil or grease the braking mechanism.**
- Take care that no ware can get into the electrical parts, drive or connections (LH Lift)
- Pay attention that the annual check of the lifts is carried out by a competently authorized person. Closing components and safety parts should be replaced when necessary. Only original spare parts/components should be used.
- The ALP-Material-Lifts must be checked at least once a year by a competent expert, but possibly more according to the working conditions and hours of operation (annual operational safety check according to Accident Prevention laws)

10. Procedures in case of malfunction

Before work begins, check that the mast parts ascend in the correct order. First of all the sliding carriage must lift up, then the front mast, after that the 2nd mast and so on. The correct order of descend is vice versa. If the order changes, the this must be immediately checked:

Possible causes:

- The wire rope has jumped of the roller
- Rollers on the rollers bearing are defect
- The roller is not turning correctly, or not at all
- Dirt or rubbish has got between the mast parts or onto the rollers
- The mast rope or the sliding carriage is damaged
- Overloading
- One-side loading

It is absolutely necessary that the cause is eliminated and the correct order is again re-established. We will be happy to deal with any queries and you can contact us at any time.

LH-Lift:

- Is the rank ventilation valve opened ?
- Is the rail safety-device de-railed ?
- Is the electricity supply security ok ?
- Is the oil level correct ?,

11. Spare parts

Only original spare parts are to be used, otherwise no guarantee claims are valid and the safety of the lifts can no longer be assured. Changes and additions, which have not been carried out by us, release us from any responsibility or possible damage claims. In the case of repair or spare parts please contact us.

12. Safety regulations

When operating the ALP load assembly lifts the operational instructions and the accident prevention regulations must always to be followed.

13. Technical Data

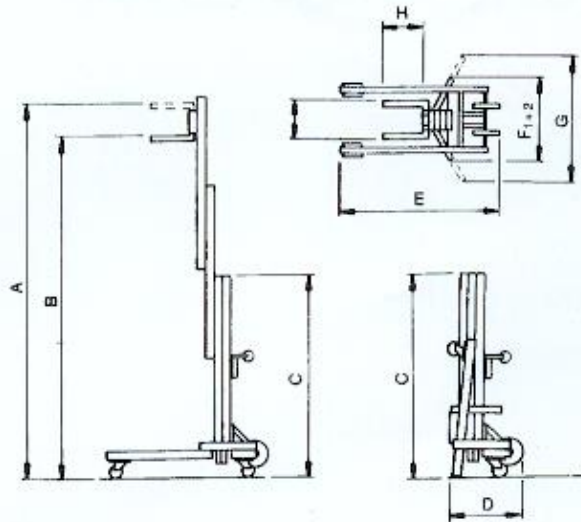

Model			LM ¹ /LH ² /LE ³				LMC ¹					LMX ¹
			400	575	600	750	300	380	450	500	600	500
Load bearing capacity	kg		300	300	300	300	250	250	250	250	250	500
Maximum lifting height												
Upper load fork	mm	A	3960	5720	6210	7470	3360	3920	4830	5120	6290	4800
Lifting height												
Lower load fork	mm	B	3570	5330	5820	7080	2970	3530	4440	4730	5900	4350
Dimensions of load fork												
Length	mm	H	650	650	650	650	650	650	650	650	650	650
Width	mm	I	560	560	560	560	560	560	560	560	560	560
Dimensions of the lift in operation												
Chassis width	mm	F1	760	760	760	760	760	760	760	760	760	760
Chassis length	mm	E	1585	1785	1785	2005	1455	1455	1455	1660	1525	1610
Width with outriggers extended	mm	G	1800	1800	1800	1800	1820	1820	1820	1420	1820	1920
Mast height	mm	C	2197	2197	1880	2197	1886	1600	1886	1600	1886	1970
Transport dimensions												
Width	mm	F2	760	760	760	760	760	760	760	760	760	760
Length	mm	D	880	830	780	780	720	720	760	760	760	765
Dead weight												
LM without outriggers	kg		135	158	165	178	99	110	118	128	139	199
LH without outriggers	kg		215	235	–	255	–	–	–	–	–	–
LE without outriggers	kg		185	205	–	225	–	–	–	–	–	–

1 = mechanical drive 2 = electric-hydraulic drive 3 = electric drive
 All rights reserved for alterations to construction, weights and dimensions.

14. Pictures

